

Power Tip / Power Swivel Site Dumpers

TA2E TA2SE

Dimensions

B = Overall Width
(not shown)

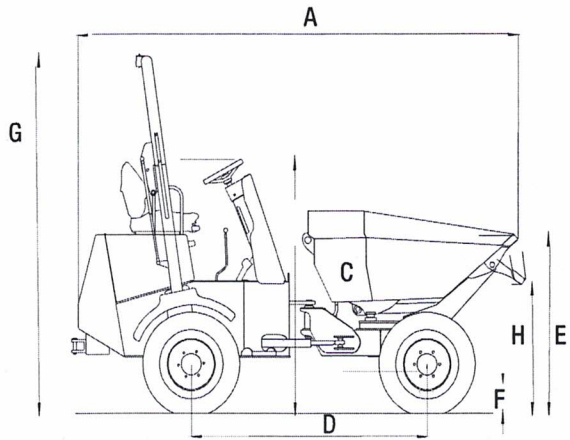

Dimensions (mm)

| | | TA2E | TA2SE |
|---|--|--------------------------------|--------------------------------|
| A | Total Length | 3550 | 3550 |
| B | Total Width (Not shown) | 1492 | 1492 |
| C | Height to Top of Steering Wheel | 1910 | 1910 |
| D | Wheelbase | 1900 | 1900 |
| E | Height to Front Lip of Skip (untipped) | 1424 | 1492 |
| F | Ground Clearance | 275 | 275 |
| G | Height to Top of ROPS (raised) | 2691 | 2691 |
| H | Height to Front Lip of Skip (tipped) | 1052 (Lowered) / 1552 (Raised) | 1120 (Lowered) / 1620 (Raised) |
| | High Discharge Height to Front of Skip | 1542 mm (Raised) | 1610 mm (Raised) |
| | Turning Radius to Outside of Skip | 3680 mm | 3680 mm |
| | Steering Angle | +/- 30.6° | +/- 30.6° |
| | Oscillation | +/- 10.5° | +/- 10.5° |
| | Tipping Type | Elevating Forward Tip | Elevating Swing Tip |

Hydraulic System (Gear Pump)

| | TA2E | TA2SE |
|--------------------|----------|----------|
| Flow rate | 21 l/min | 21 l/min |
| Operating Pressure | 210 bar | 210 bar |

Braking System

| | TA2E | TA2SE |
|---------------|--|-------|
| Working Brake | Foot Brake - Oil Immersed Discs on Front | |
| Parking Brake | Over Centre Locking - Oil Immersed Disc Front Axle | |

Standard Equipment & Options

| | TA2E | TA2SE |
|--------------------|----------|----------|
| Folding ROPS Frame | Standard | Standard |
| Reversing Alarm | Standard | Standard |
| Flashing Beacon | Standard | Standard |
| Towing Bracket | Standard | Standard |
| Site Lights | Option | Option |
| Road Lights (RTA) | Option | Option |
| Rear View Mirror | Option | Option |
| Grass Land Tyres | Option | Option |

Electrical System

| | TA2E | TA2SE |
|------------|-------|-------|
| Voltage | 12 V | 12V |
| Battery | 74 Ah | 74 Ah |
| Alternator | 55 A | 55 A |

Dealer



Terex Construction
Central Boulevard, ProLogis Park,
Coventry, England CV6 4BX

PHONE ++44 2476 339400
FAX ++44 2476 339500
EMAIL enquiries@terexce.com
WEB www.terex.co.uk

www.terex.co.uk

Effective Date: 30 November 2007. Product specifications and prices are subject to change without notice or obligation. The photographs and/or drawings in this document are for illustrative purposes only. Refer to the appropriate Operator's Manual for instructions on the proper use of this equipment. Failure to follow the appropriate Operator's Manual when using our equipment or to otherwise act irresponsibly may result in serious injury or death. The only warranty applicable to our equipment is the standard written warranty applicable to the particular product and sale and Terex makes no other warranty, express or implied. Products and services listed may be trademarks, service marks or trade-names of Terex Corporation and/or its subsidiaries in the USA and other countries. All rights are reserved. Terex® is a registered trademark of Terex Corporation in the USA and many other countries. © 2007 Terex Corporation.

DS TA2E/SE 1107-EN



Printed on material using 55% recycled fibre from both pre and post-consumer sources, together with 45% virgin ECF fibre from sustainable forests.